

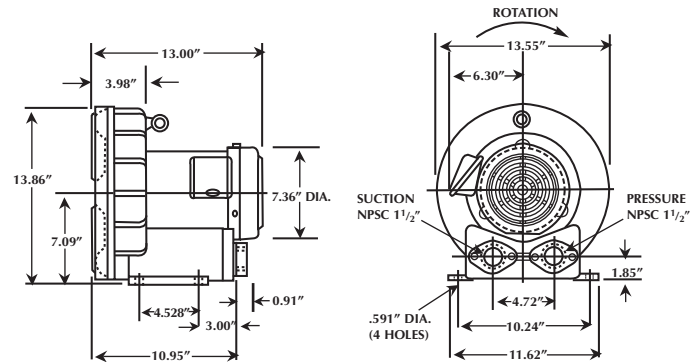

The VFC50 is a singlestage ring compressor with a maximum pressure of 80 in. H₂O, a maximum vacuum of 70 in. H₂O, and a maximum capacity of 154 SCFM. It comes complete with a direct-drive, 2.5 horsepower, TEFC motor capable of operating on a wide range of voltages, and on 50 or 60 Hz. A pilot-duty thermal protector is standard equipment on all 3-phase and 1-phase models. All versions have NEMA class B insulation, are UL recognized, CSA certified, and CE. 575 Volt units are CSA certified only.



SPECIFICATIONS

1 Phase	Model No.	Hz	Voltage		Amps (Max. Rated)	Amps (Locked Rotor)	Max. Pressure in. H ₂ O	Max. Vacuum in. H ₂ O	Max. Airflow SCFM	Min. Airflow SCFM	Max. Temp Rise (ΔT) °F(°C)	Weight lbs.(kg)
			Low Voltage/High Voltage									
1 Phase	VFC508P-2T	60	200/230		12-11	70-80	80	70	154	60	72(40)	97.5(44)
		50	200/230		8.5-8	70-75	60	53	130	45	65(35)	

ACCESSORIES

Description	Vacuum Relief Valve	Pressure Relief Valve	Inlet Filter	Inlet Filter Cover	Inlet Filter/Receiver	Exhaust Silencer/Muffler
Model No.	VV5	PV5	F-45	C-45	R30P1.5	VFY-024A

NOTE: Maximum allowable time at deadhead is 60 seconds.



VFC50 PERFORMANCE DATA

KEY

— 60 Hz
— 50 Hz

PRESSURE

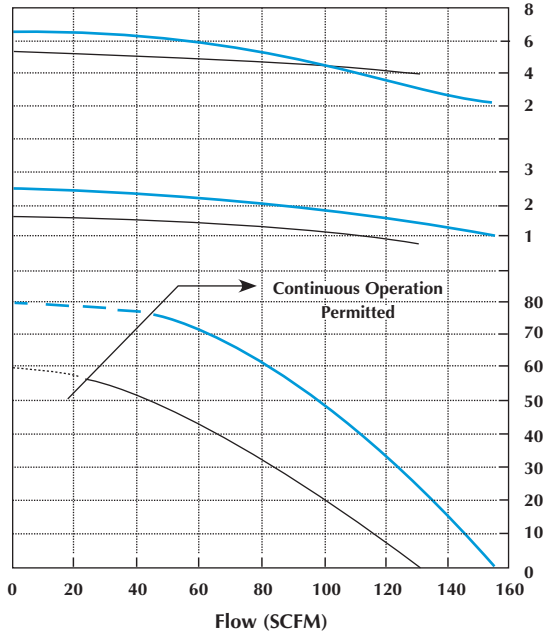

VACUUM

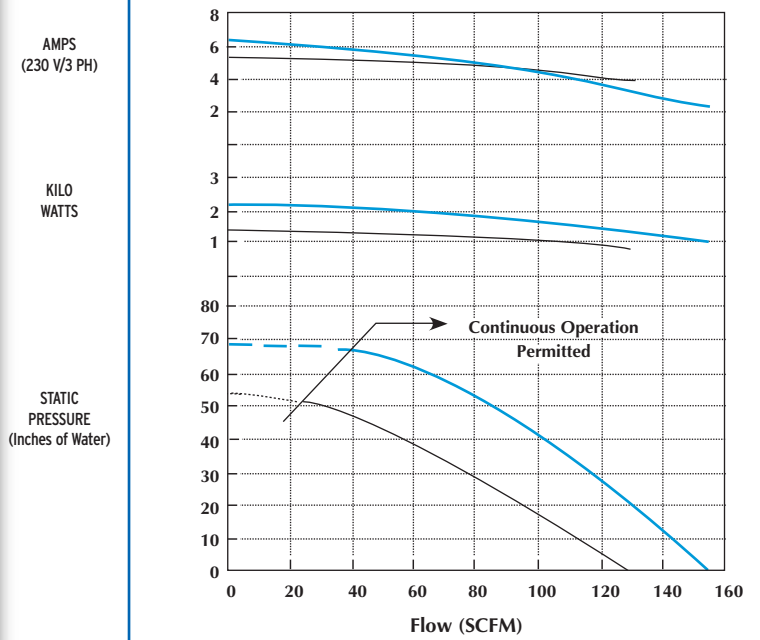

TEMPERATURE RISE

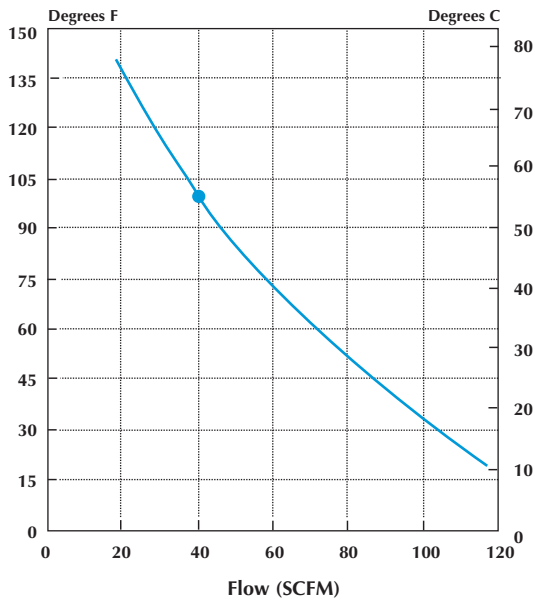

SOUND LEVEL

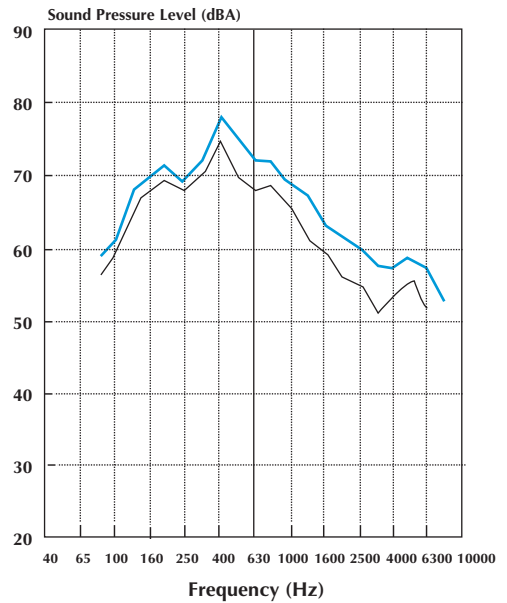

Max. Air Temperature is Value Marked • plus 40 Degrees C Ambient Temperature

*Measured at distance of 1.0 meter