

## **CARY Super Vac Portable and Stationary Vacuum Systems**

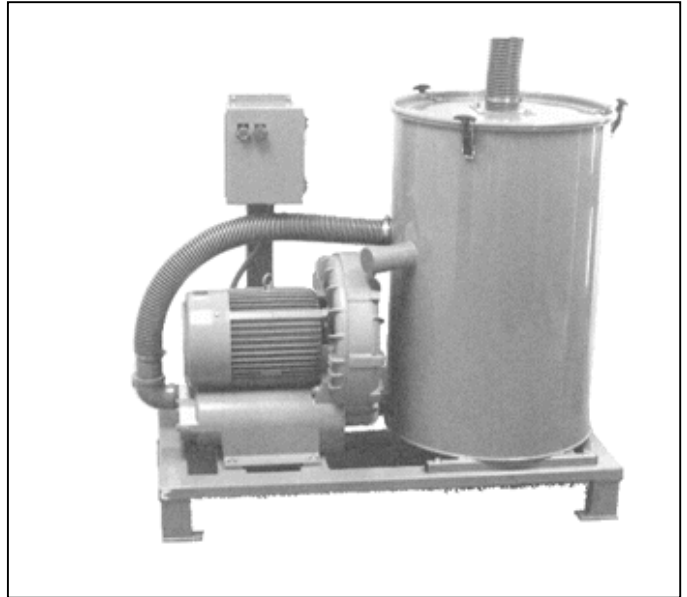
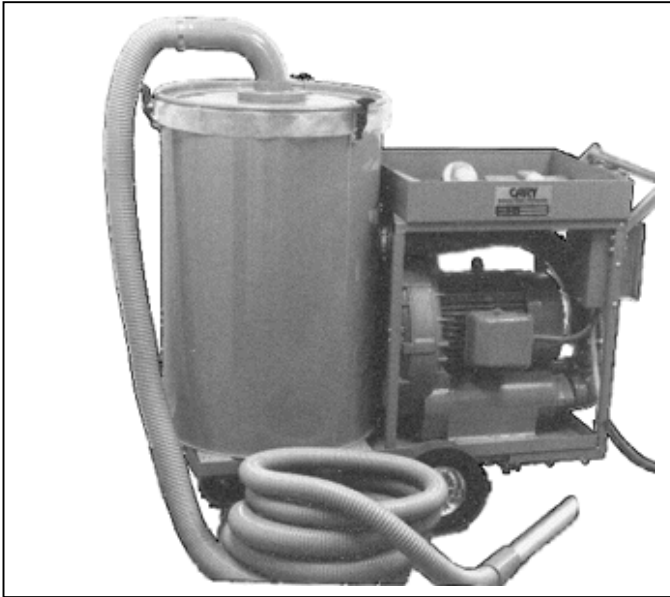

The **CARY Super Vac System** is designed to provide years of trouble-free service and continuous duty in industrial applications. Two versions are available, the portable unit which is mobile and can be moved to any location and the stationary unit for central vacuum headers or limited area cleanups.

The **CARY Super Vac System** were designed and developed for efficient clean up and removal of light weight waste. The systems have been used to pick up and clean areas of: textile waste, fibers and lint, fiberglass, crumbs, cereals, sawdust and wood chips, including dust and dirt.

A Canton flannel (cotton flannel on canvas) filter bag, with a filtration area of 2400 sq. inches accomplishes the vacuum receiver filtration. The filter bag is clamped into the receiver and is supported by a perforated cylinder. The disposable/reusable bags, also, provide filtration and are placed inside the Canton flannel filter bag. The vacuum receivers are "top-loading." The waste products are collected in 10 mil Serex disposable/reusable bags. The bags are lifted up and out to empty.

### **CARY Super Vac Portable and Stationary Systems feature:**

- High Capacity, 7.9 Cu. Ft.
- Stationary and Portable Configurations
- No Maintenance Required
- Low Noise
- High Air Flow and Suction
- Highly Reliable Fuji Regenerative Blower

## CARY Super Vac Specifications

Model Number	CV604 P or S	CV804P or S
Motor Horse Power	4.5 HP	10 HP
Sealed Water Lift	100 inches WG	110 inches WG
Rating at 1" Orifice	145 SCFM	275 SCFM
Rating at 2" Orifice	195 SCFM	360 SCFM
Vac Relief Valve Set	90 inches WG	100 inches WG
Mag. Motor Starter	Yes	Yes
Waste Capacity, Cu. Ft.	7.9	7.9
Motor Efficiency %	At Full Load 87.5%	At Full Load 88.5%
Full Load Watts	2.6 KW	6.4 KW
Voltage	230/460/575V	230/460/575V
Phase	3	3
Frequency	60	60
Weight (lb.)	350	525

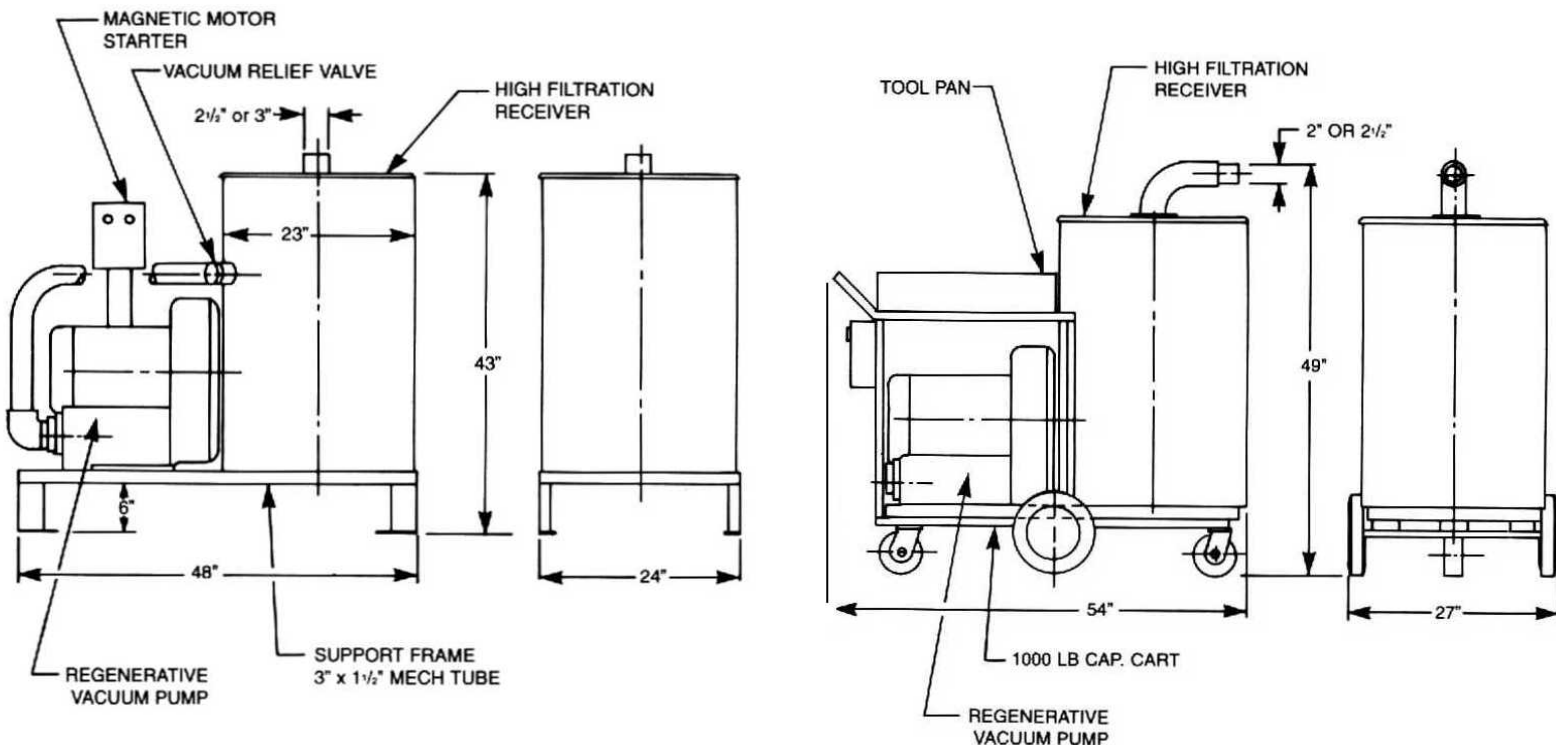

Standard accessories include:

- 1 Spare Canton Flannel Filter Bag
- 10 Spare Disposable/Reusable Bag

The portable unit, also, includes hose, flexible S.O. cord and tools  
(See specific situations)