

RING COMPRESSORS

OPERATION AND PARTS MANUAL

[OTH SERIES & 4TH SERIES]

Thank you for purchasing our Fuji Ring Compressor.
Our product is produced with high quality materials and manufacturing processes. Our superior workmanship will give you the best product available in the air moving market place. Please read the instructions carefully prior to usage.

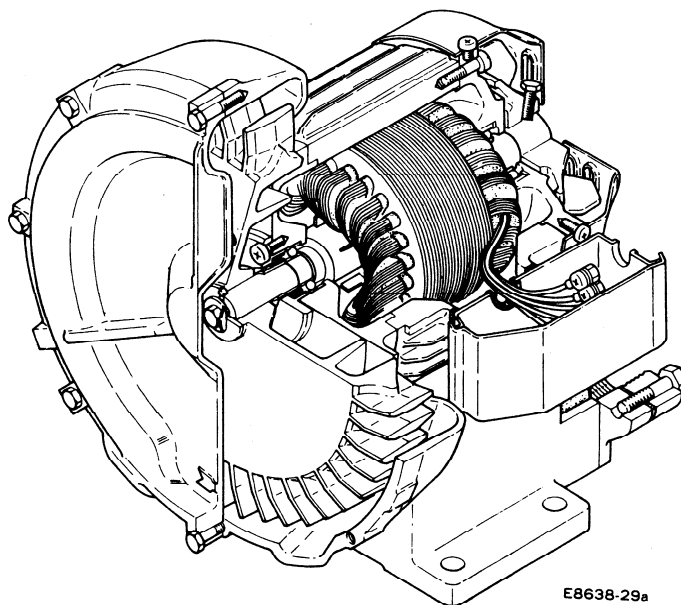

INV-YH309a

Fuji Electric Co.,Ltd.

E8638-77-1

OPERATING INSTRUCTIONS

Handling gases

The Ring Compressors are used to handle non-combustible, non-corrosive and non-explosive gases and air. The inlet and ambient air or gas temperature should be less than 104°F (40°C), and the relative humidity not to exceed 80%.

Installation

The Ring Compressors can be installed in any direction. When installed vertically, the motor side should upward. VFC704A, 804A and VFC904A should be installed horizontally.

Do not install The Ring Compressors on a base which is subject to or creates vibration. The mounting base should be rigid enough to prevent resonance. Use vibration-insulator bases or pads if necessary.

The allowable limit of vibration is shown in the figure.

Filtration

Air and gases should be filtered before entering the blower by using an intake or inline filter as recommended in The Fuji literature or by The Fuji distributor or representatives. Care should be taken not to get dirt or particles be sucked into The Ring Compressor.

Direction of rotation

The Ring Compressors should be rotated in the "Arrow" direction as noted on the casing. All units rotate in a clockwise direction as viewed from the motor side. You may observe the rotation by looking at the motor fan or shaft direction. The vacuum connection is marked "IN". The pressure connection is marked "OUT" on the flange.

The three phase units can be run in the reverse or counter-clockwise direction by reversing L1 and L3, but performance is reduced.

The single phase units operate in the clockwise direction only.

Electrical connection

A qualified electrician should make the connection and knows the local electrical codes. Connections should be made as per the nameplate and operation instruction connecting diagram on page 5.

For all three phase units a magnetic motor starter should be used with thermal overload protection. The VFC400P-5T and VFC504P-2T requires a definite purpose contactor.

Caution: Please consult your local electrical codes, through a certified electrician or electrical contractor.

Temperature rise

The temperature of the air passing through The Ring Compressors will rise as shown in the figures below.

Continuous operations

The Ring Compressors pressure, vacuum and flow can be adjusted from open flow (free air) to shut-off.

The minimum flow and maximum shut-off times must be met.

The Ring Compressors must operate within the continuous operating conditions specified in the table.

we recommend our pressure and vacuum relief valves or by-pass hole to prevent shut-off for long periods of time.

The temperature rise of the air passing thru The Ring Compressor (60Hz)

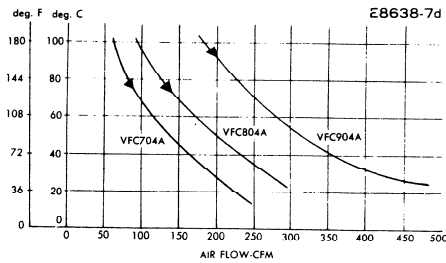
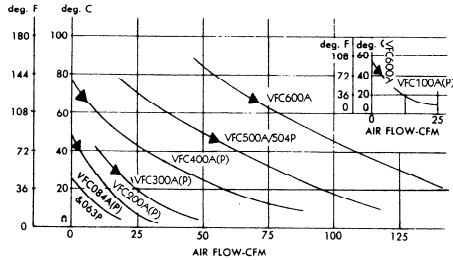

Maintenance

Clean the inside and outside (particularly the air path of the cooling fan) of The Ring Compressors to remove dirt and dust. This may result in abnormal temperature rise, loss of performance or increase of vibration.

Parts

The bearings, oil-seal and silencer are subject to wear. These parts should be replaced with new ones as necessary. The impeller, casing, gasket and wire net may also need replacement depending on the operating conditions.

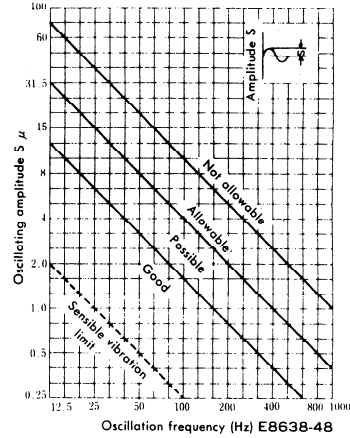

Shut-off allowable time and minimum required airflow for continuous operation E8638-30c

Model	Pressure		Vacuum	
	sec①	CFM②	sec①	CFM②
VFC063P	Cont.	0	Cont.	0
VFC084A, 084P	Cont.	0	Cont.	0
VFC100A, 100P	600	3.5	600	3.5
VFC200A, 200P	240	3.5	240	3.5
VFC300A, 300P	120	17	120	16
VFC400A, 400P	120	3.5	120	3.2
VFC500A, 504P	60	45	60	40
VFC600A	60	56	60	50
VFC704A	30	88	30	70
VFC804A	30	135	30	106
VFC904A	30	195	30	140

- ① Shut-off allowable time (sec) starting at normal temperature.
- ② Minimum required air flow.
- ③ We suggest that vacuum or pressure relief valves be installed to prevent shut-off conditions on VFC300A / P units and larger.

Note: Limited maximum air temperature is temperaturerise value marked (▲) +40°C (Ambient temperature)

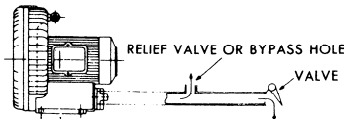

BYPASS (Pressure Use) E8638-9a

VFC084A, VFC100A thru VFC600A, VFC063P thru VFC400P and 504P assembly diagram

VFC100P
thru VFC400P

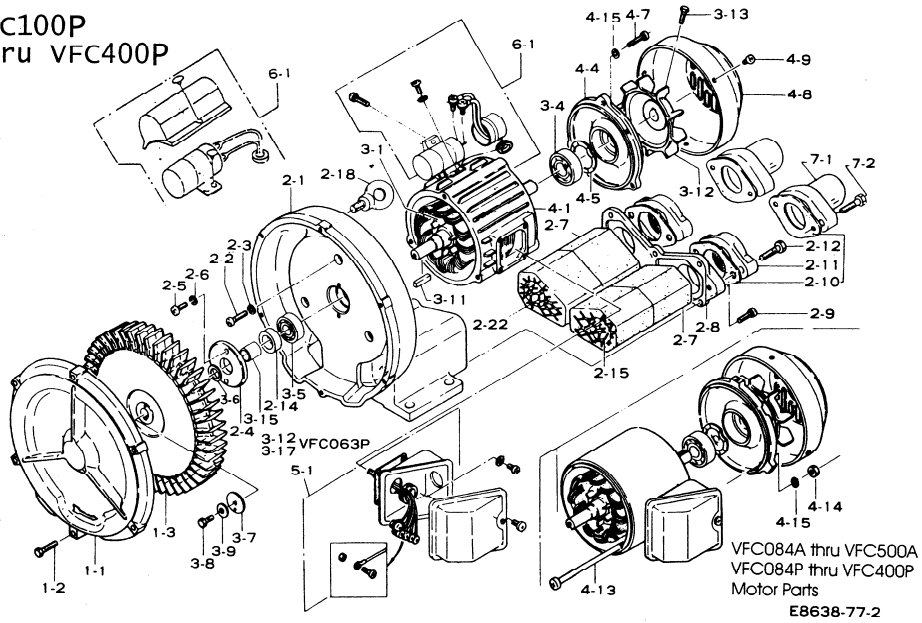

VFC704A thru VFC904A assembly diagram

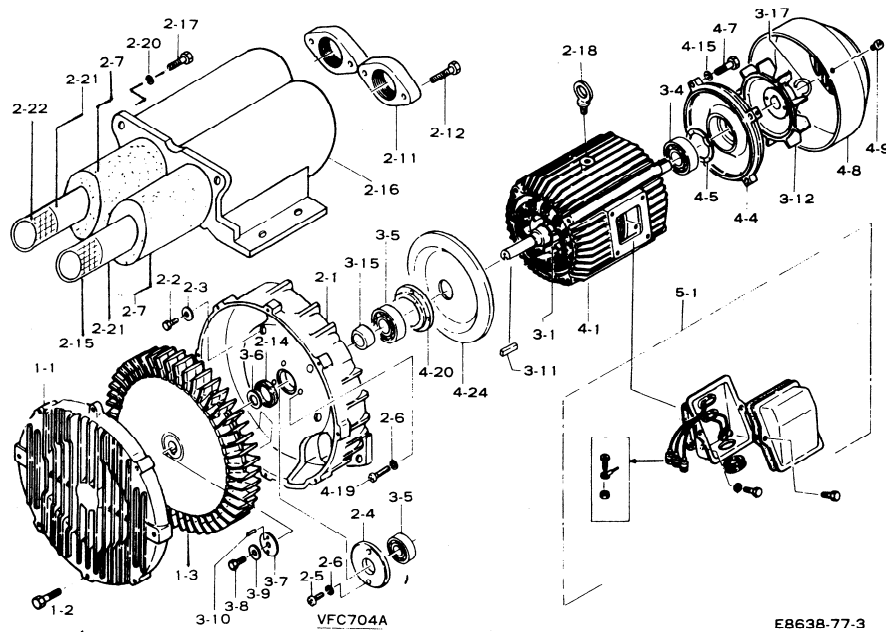

TROUBLE SHOOTING

		POSSIBLE CAUSE ^{*3Phase Units} ^{**1Phase Units}	REMEDY
IMPELLER DOES NOT TURN	HUMMING SOUND	<ol style="list-style-type: none"> *One phase of power line not connected. *One phase of stator winding open Bearings defective Impeller jammed by foreign material Impeller jammed against housing or cover **Capacitor open 	<ol style="list-style-type: none"> Connect Contact Factory Change bearings Clean Adjust Change capacitor
	NO SOUND	<ol style="list-style-type: none"> *Two phases of power line not connected. *Two phases of stator winding open 	<ol style="list-style-type: none"> Connect Contact factory
IMPELLER TURNS	BLOWN FUSE	<ol style="list-style-type: none"> Insufficient fuse capacity Short circuit 	<ol style="list-style-type: none"> Use fuse of proper rating Repair
	MOTOR OVERHEATED OR PROTECTOR TRIPS	<ol style="list-style-type: none"> High or low voltage *Operating in single phase condition Bearings defective Impeller rubbing against housing or cover Impeller or air passage clogged by foreign material Unit operating beyond performance range Capacitor shorted *One phase of stator winding short circuited 	<ol style="list-style-type: none"> Check input voltage Check connections Change bearings Adjust Clean Contact factory Change capacitor Contact factory
	ABNORMAL SOUND	<ol style="list-style-type: none"> Impeller rubbing against housing or cover Impeller or air passages clogged by foreign material Bearings defective 	<ol style="list-style-type: none"> Adjust Clean Change bearings
	PERFORMANCE BELOW STANDARD	<ol style="list-style-type: none"> Leak in piping Piping and air passages clogged Impeller rotation reversed Leak in Compressor Low voltage 	<ol style="list-style-type: none"> Tighten Clean Check wiring Tighten cover, flange Check input voltage

CONNECTIONS

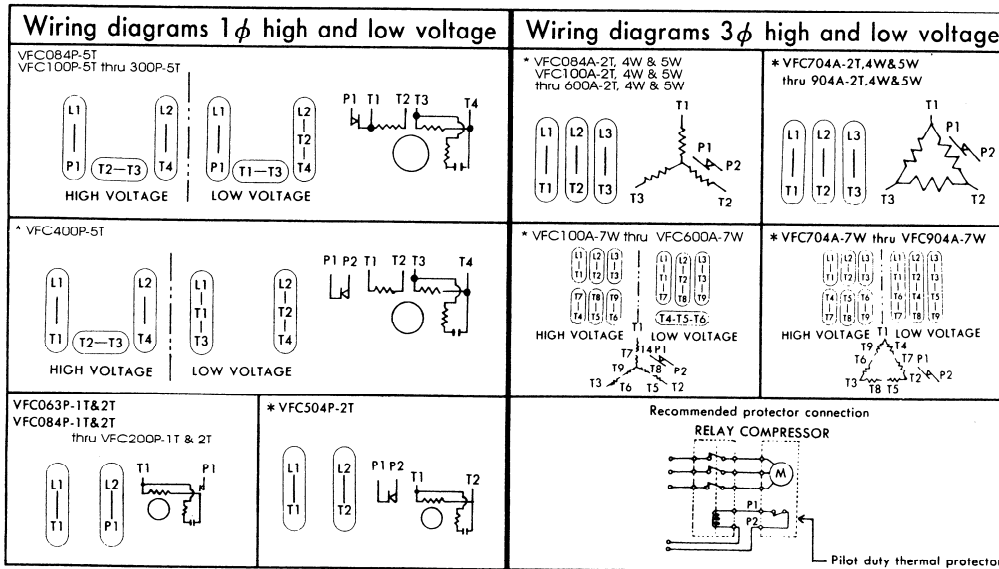

(Note) 1. The marking * :Pilot duty thermal protector.
 2. Model VFC504A-2T may not be equipped with thermal protector. Please check it on the nameplate.
 3. All 3-phase units use magnetic starter.

E8638-77-5



WARNING !

This blower is designed to operate indoors, and is an environment that is a water-free and dust-free.

This blower is only a component, it must be installed in a machine or part of a machinery which meets the terms of the Machine directive 89/392/EEC. Commission will not occur until the end product or machinery conforms with the guidelines in EN60204-1.

WARRANTY

FUJI ELECTRIC CORP. OF AMERICA warrants that FUJI RING COMPRESSOR is free from defects in material and workmanship at the time of shipment. This warranty covers the period for eighteen months from the date of shipment or one year from the date of installation, whichever comes first. Thermal protector must be connected as recommended.

The product or parts found to be defective in materials or workmanship during this period will be repaired or replaced at no charge.

This warranty does not apply to any product or parts subjected to damage in transit, accident, misuse or abuse.

Fuji Electric Co.,Ltd.

HEAD OFFICE: GATE CITY OHSAKI, EAST TOWER, 11-2,
OSAKI 1-CHOME SHINAGAWA-KU,
TOKYO 141-0032, JAPAN

TELEPHONE: TOKYO 3-5435-7139 FAX: TOKYO 3-5435-7460

FUJI ELECTRIC CORP. OF AMERICA

FUJI

ELECTRIC

Fuji Electric Corp. of America

Park 80 West Plaza II
Saddle Brook, NJ 07663